

**SERVICE MANUAL  
PILOTLESS ELECTRONIC WATER HEATERS**



1.- NO IGNITION No spark present. ....	2
2.- NO IGNITION Water Heater sparking but the burner does not ignite. ....	3
3.- THE WATER FLOW IS VERY LOW .....	3
4. CONTINUOUS SPARKING WHEN WATER HEATER IS IGNITED .....	4
5.- SPARKING, BURNER IGNITES FOR A FEW SECONDS AND THEN SWITCHES OFF.....	4
6.- HARD IGNITION OF THE WATER HEATER THERE IS NO SOFT START.....	5
7.- WATER HEATER CONTINUES SPARKING WHEN TAP IS TURNED OFF.....	5
8.- WATER HEATER SWITCHES OFF AFTER FEW MINUTES OF OPERATION.....	6
9.- WATER HEATER REMAINS IGNITED WHEN TAP IS CLOSED .....	7
10.- FLAMES IN BURNER ARE YELLOW .....	7
11.- THE BATTERY LIFE IS VERY SHORT .....	8
12.- USEFUL DATA.....	9
13.- IGNITION SEQUENCE .....	10
14.- PHOTO GALLERY .....	11

<i>SYMPTOM</i>	<i>POSSIBLE CAUSE OF FAILURE</i>	<i>SOLUTION</i>
<b>No Spark</b>		
<b>All models</b>	Check there is a battery in the Battery Box	Insert a full battery in the Battery Box. <b>Photo 1</b>
	Check that the battery is placed in the Battery Box in the correct position	Correct the position of the Battery. <b>Photo 1.</b>
	The switch in the electronic circuit is in off position.	Turn the switch on (inner position). <b>Photo 4</b>
	The micro switch is not correctly connected or the connectors are loosened.	Check the status of the micro switch connection. <b>Photo 7</b>
	Low water pressure. The main gas valve is not opening.	Check the water pressure. Change the position of the temperature selector to Max. temperature. ( Min Water Flow) <b>Photo 4</b>
	The water inlet filter is dirty. The Water Flow is very low.	Clean the water filter. <b>Photo 3</b>
	The micro switch is not working correctly.	Disconnect the micro switch from the circuit. Shut off the gas inlet. Short circuit the terminals in the electronic circuit. The circuit must generate spark if circuit is O.K. Adjust / Change the micro switch. In case it is necessary.
	High ambient humidity. No sparking between electrodes.	Dry the electrodes and clean them. <b>Photo 5</b>
	The spark electrode wires have lost their insulation. Sparking is taking place between the wires and earth or between the two wires. The electrode connector is defective.	Replace the electrode unit. <b>Photo 5</b>
	The Ground connection of the electronic circuit is not correctly connected. --> The Servo hasn't any Voltage.	Tighten the ground connection terminal. <b>Photo 6</b>
	Wires not well connected to electronic circuit.	Check the wiring installation.
	TTB switch in Draught diverter is tripped	Check that TTB is not Tripped (Tripped means contact opened).
	Water valve diaphragm broken. Communication channel between chambers obstructed.	Disassemble Water Valve. Change the diaphragm. Clean the communication channel. <b>Photo 8.</b>
Venturi obstructed.	Check and change venturi. <b>Photo 9.</b>	

<i>SYMPTOM</i>	<i>POSSIBLE CAUSE OF FAILURE</i>	<i>SOLUTION</i>
<b>No Spark</b>		
<b>All models</b>	Water valve O-rings are blocked.	Disassemble Water Valve. Work the water pin manually to unblock them / Change the top cover of the water valve. <b>Photo 10.</b>
	Main gas valve seal is blocked.	Work the gas pin manually to unblock the O-ring. <b>Photo 11.</b> Change Gas valve.

## 2.- NO IGNITION

## Water Heater sparking but the burner does not ignite.

<i>SYMPTOM</i>	<i>POSSIBLE CAUSE OF FAILURE</i>	<i>SOLUTION</i>
<b>It sparks but the burner does not ignite</b>	Battery Voltage very low. Sparkling is very at low frequency and sounds very weak.	Replace Battery. Use Alkaline battery. <b>Photo 1</b>
	Battery is not correctly inserted in the Battery box.	Check position of the Battery. <b>Photo 1</b>
	No gas. Low gas pressure.	Open gas valve. / Check gas pressure.
	Main Gas Valve is not opened. Microswitch needs adjustment	Adjust Microswitch. Must be activated only with main valve opened
	The spark is not generated in the sparking electrode.	Check humidity on electrodes. <b>Photo 5.</b> Check position of electrodes or whether they are deformed.
	There is no voltage in Servo valve terminal.	Check the Electronic circuit earth connection. <b>Photo 6.</b> Check the wiring. Change the Electronic circuit.
	In case there is voltage in servo terminal.	Change the gas valve. The servo is incorporated in the gas valve.

## 3.- THE WATER FLOW IS VERY LOW

<i>SYMPTOM</i>	<i>POSSIBLE CAUSE OF FAILURE</i>	<i>SOLUTION</i>
<b>The water flow is very SMALL and the water is coming out VERY HOT.</b>	Water pressure is too low.	Change the position of the water selector to MAX.. <b>Photo 4</b>
	The water filter is dirty.	Clean the water filter. Change the water filter. <b>Photo 3.</b>
	The heat exchanger in combustion chamber is obstructed.	Clean the heat exchanger. Change the combustion chamber.

#### 4. CONTINUOUS SPARKING WHEN WATER HEATER IS IGNITED

<i>SYMPTOM</i>	<i>POSSIBLE CAUSE OF FAILURE</i>	<i>SOLUTION</i>
Continuous sparking and burner is ignited	The electronic circuit is not working correctly.	Replace the Electronic circuit. <b>Photo 2.</b>

#### 5. - SPARKING, BURNER IGNITES FOR A FEW SECONDS AND THEN SWITCHES OFF

<i>SYMPTOM</i>	<i>POSSIBLE CAUSE OF FAILURE</i>	<i>SOLUTION</i>
The burner switches off after remaining on for a few seconds	Air in gas pipes.	Purge air from gas pipes.
	Low gas pressure.	Check gas pressure.
	The electrode unit has come loose.	Tighten the electrode fixing screw. <b>Photo 5.</b>
	The electrode flame sensor is out of position.	Change the electrodes.
	The electrode flame sensor is deformed. See manual: electrodes life....	Change the electrodes.
	The electrode connector is not properly connected.	Check the connection of this connector. <b>Photo 7 &amp; Photo 13.</b>
	The electronic circuit Ground terminal is not properly connected.	Tighten the Ground connection terminal. <b>Photo 6.</b>
Electronic circuit is defective. No Voltage in Servo terminal	Change the electronic circuit.	
Servo Valve is defective	Check Voltage in Servo terminal. <b>Photo 17.</b>	

## 6.- HARD IGNITION OF THE WATER HEATER THERE IS NO SOFT START

<i>SYMPTOM</i>	<i>POSSIBLE CAUSE OF FAILURE</i>	<i>SOLUTION</i>
<b>The burner ignites WITHOUT SOFT START</b>	Battery Voltage very low. Sparking is very at low frequency and sounds very weak.	Replace Battery. Use Alkaline battery. <b>Photo 1.</b>
	The electrodes are not correctly fixed to the manifold. They are too high referred to the burner blades.	Fix the electrodes correctly using the fixing screw. <b>Photo 5.</b>
	There is a gas accumulation in the combustion chamber	Electronic circuit defective, there is servo voltage with no Flame. Check Servo valve closes when no energized.
	There is air in the gas supply line.	Drain the gas circuit.
	Excessive gas pressure.	Check the gas inlet pressure <b>Photo 17.</b> Nominal gas Pressure 13 mbar. Check / adjust the gas pressure in the burner <b>Photo 12.</b>
	The Ground terminal of the electronic circuit is not properly connected.	Tighten the Ground connection terminal. <b>Photo 6.</b>
	Defective wiring of electronic circuit.	Check the wiring and change it if necessary.
	The servo is not working correctly. No soft start function	Change the gas valve. The Servo is integrated in the gas valve. <b>Photo 17.</b>
	The nozzles are not well fitted.	The change of gas type has not been made correctly.

## 7.- WATER HEATER CONTINUES SPARKING WHEN TAP IS TURNED OFF

<i>SYMPTOM</i>	<i>POSSIBLE CAUSE OF FAILURE</i>	<i>SOLUTION</i>
<b>The water heater is sparking when the tap is turned off.</b>	Micro switch not properly adjusted.	Check micro switch adjustment. Microswitch adjustment screw <b>Photo 17.</b>
	The micro switch has broken (The contacts are stuck). Sparkling only occurs for 5 seconds.	Check function of micro switch Change the micro switch <b>Photo 17 -</b>
	The Electronic circuit is faulty.	Change the Electronic circuit <b>Photo 2.</b>

## 8.- WATER HEATER SWITCHES OFF AFTER FEW MINUTES OF OPERATION

<i>SYMPTOM</i>	<i>POSSIBLE CAUSE OF FAILURE</i>	<i>SOLUTION</i>
<b>Water heater switches off after few minutes of operation</b>	Low Battery Voltage	Replace the Battery. <b>Photo1.</b>
	Gas pressure/flow insufficient.	Check burner gas pressure. <b>Photo 18.</b>
	Drop in water pressure during functioning of the water heater.	Check the water pressure.
	The TTB sensor is Tripped. Smoke exhaust defective	Check the status of the TTB sensor. <b>Photo 16.</b>
	The water filter is dirty.	Check the status of the water filter. Change or clean it if necessary. <b>Photo 3.</b>
	Membrane in water valve broken.	Change the membrane. <b>Photo 8.</b>
	Venturi dirty / obstructed.	Remove and check the venturi. Change it if necessary. <b>Photo 9.</b>
	The electrode unit has become loose.	Tighten the electrode fixing screw. <b>Photo 5.</b>
	The electrode connector is not properly connected.	Check the connection of this connector. <b>Photo 2 and 13.</b>
	The Ground terminal of the electronic circuit is not correctly connected.	Tighten the Ground connection terminal. <b>Photo 6.</b>
	Electronic circuit is defective.	Change the control circuit.
The Servo is defective.	Test Voltage in Servo. Change the gas valve in case there is no function. The servo is integrated in the gas valve. <b>Photo 17 and 18</b>	

## 9.- WATER HEATER REMAINS IGNITED WHEN TAP IS CLOSED

This is a DANGEROUS situation because the Pressure and Temperature in the combustion chamber will increase very fast,

**DISCONNECT THE GAS SUPPLY TO THE WATER HEATER.**

PERMANENT DAMAGES AND DEFORMATIONS IN WATER VALVE AND COPPER PIPES.

<i>SYMPTOM</i>	<i>POSSIBLE CAUSE OF FAILURE</i>	<i>SOLUTION</i>
The water heater remains ignited when the tap is turned off.	Water Valve shaft blocked.	Check the water valve/change the top cover of the water valve. <b>Photo 10.</b>
	Communication channel between chambers obstructed.	Clean the communication channel. <b>Photo 8</b>
	Water leak from upper cover - rust in water neck blocking up the pins.	Change the water and gas valves.
	Main regulator of open selector in water valve is blocked..	Check the regulator move freely in their housing. <b>Photo 9</b> Change the Water Valve if necessary
	Venturi obstructed.	Check / change venturi. <b>Photo 9</b>
	Gas shaft blocked.	Check the gas pin O-ring / change the O-ring <b>Photo 11.</b>

## 10.- FLAMES IN BURNER ARE YELLOW

<i>SYMPTOM</i>	<i>POSSIBLE CAUSE OF FAILURE</i>	<i>SOLUTION</i>
Burner flames are yellow	Excessive gas pressure.	Check gas pressure at the water heater inlet and at the burner. Adjust Burner Pressure. <b>Photo 12, 17 and 18.</b>
	Dirt in burner.	Clean the burner.
	Unsuitable nozzles. The gas change has not been made correctly.	Replace the nozzles.
	Burner incorrectly assembled or misaligned.	Adjust burner or align it.

## 11.- THE BATTERY LIFE IS VERY SHORT

<i>SYMPTOM</i>	<i>POSSIBLE CAUSE OF FAILURE</i>	<i>SOLUTION</i>
The Battery life is very short	Some of the wirings is damaged and is in contact with a metallic part of the water Heater	Review status of wirings. Change electrical installation if necessary
	The servo valve current consumption is very high	Servo valve defective. Change gas valve.
	The servo valve is always opened.	Electronic circuit defective / Replace Electronic circuit. <b>Photo 2</b>
	Electronic circuit defective.	Replace electronic circuit. <b>Photo 2.</b>
	A Saline Battery has been used.	Battery must be Alkaline.



# Electrolux



## 12. - USEFUL DATA

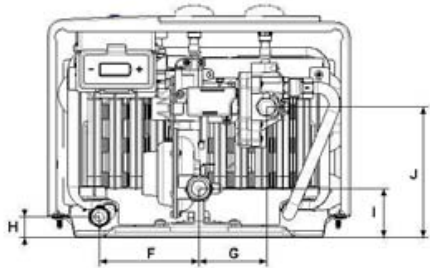

DIMENSIONS											
A	B	C	D	E	F	G	H	I	J	K	L
310	578	228	240	112	102	69,4	21	50	133,8	210	115,6

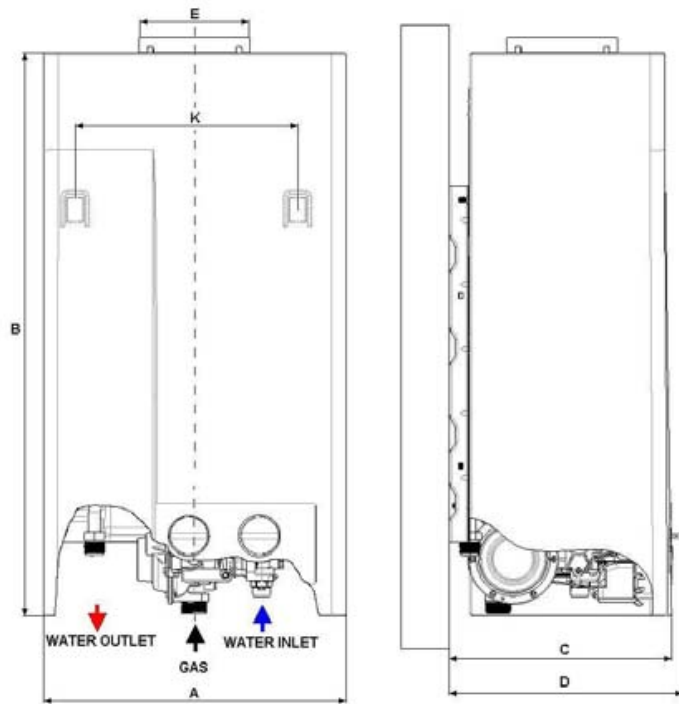

<b>GAS INLET PRESSURE</b>	
NATURAL G20	13mbar
<b>BURNER PRESSURE</b>	
	10,8 mbar
<b>WATER PRESURE</b>	
Maximum	13 bar
<b>Minimum OS</b>	0,25 bar
<b>Minimum CS</b>	0,15 bar

<b>GAS</b>	3/4"
<b>WATER INLET</b>	3/8"
<b>WATER OUTLET</b>	1/2"
<b>EXHAUST</b>	
Chimney Diameter	112 mm internal

# 13. - IGNITION SEQUENCE

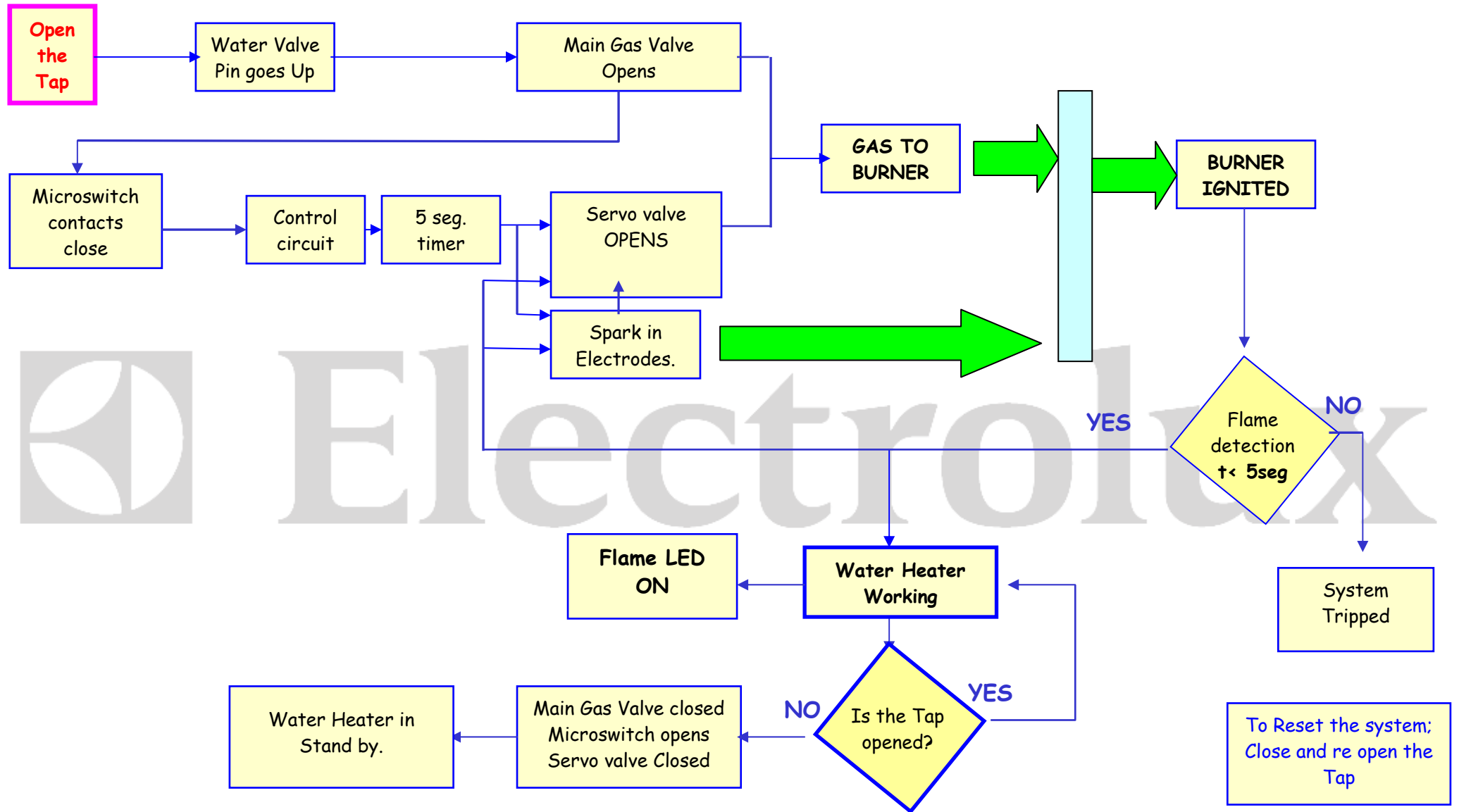

## 14. - PHOTO GALLERY

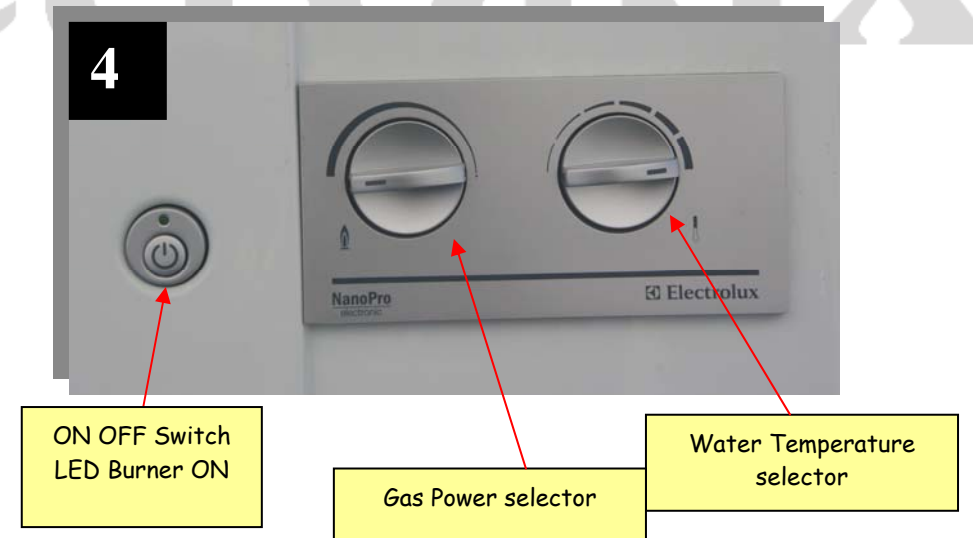
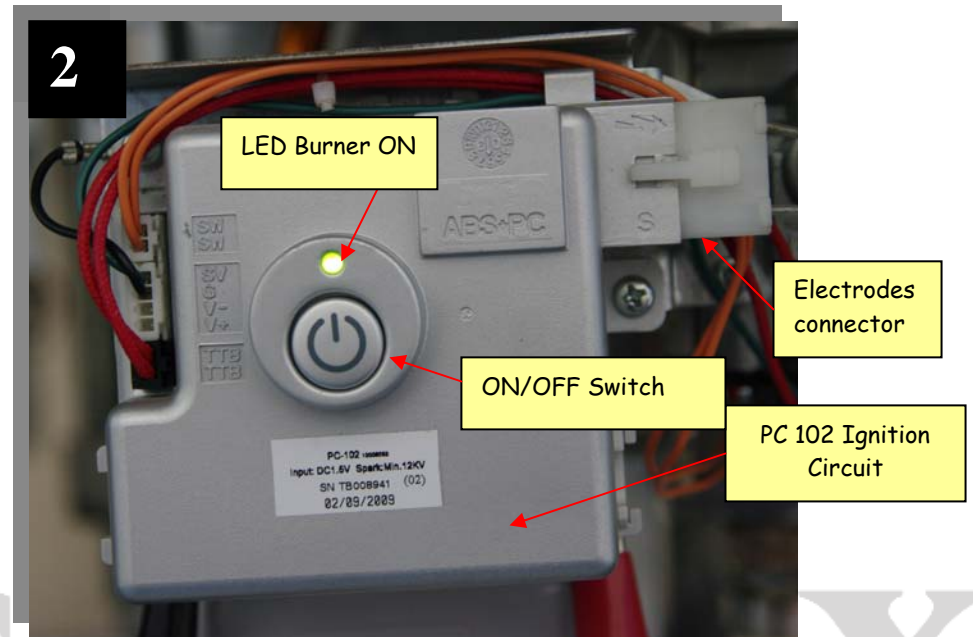
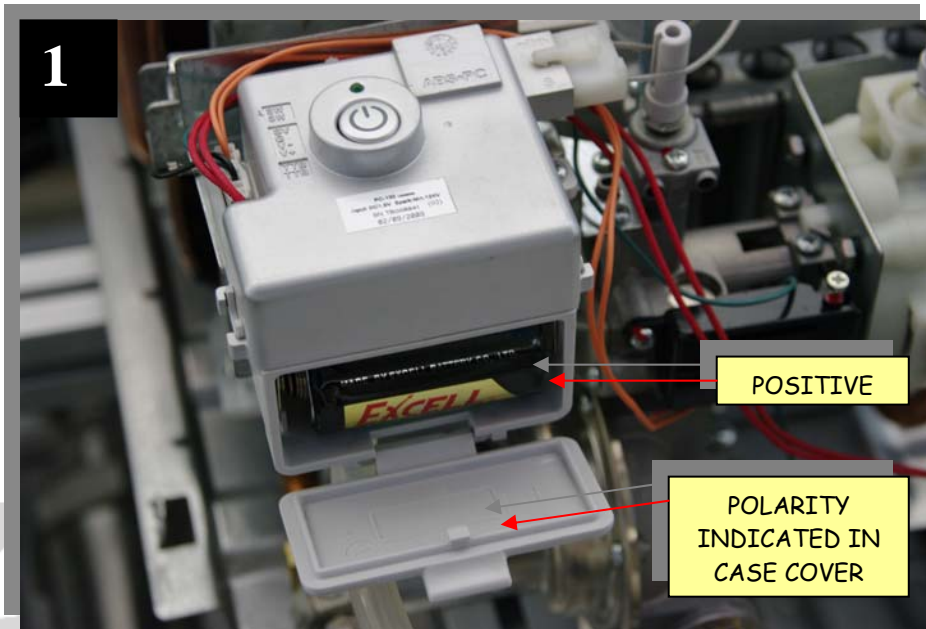

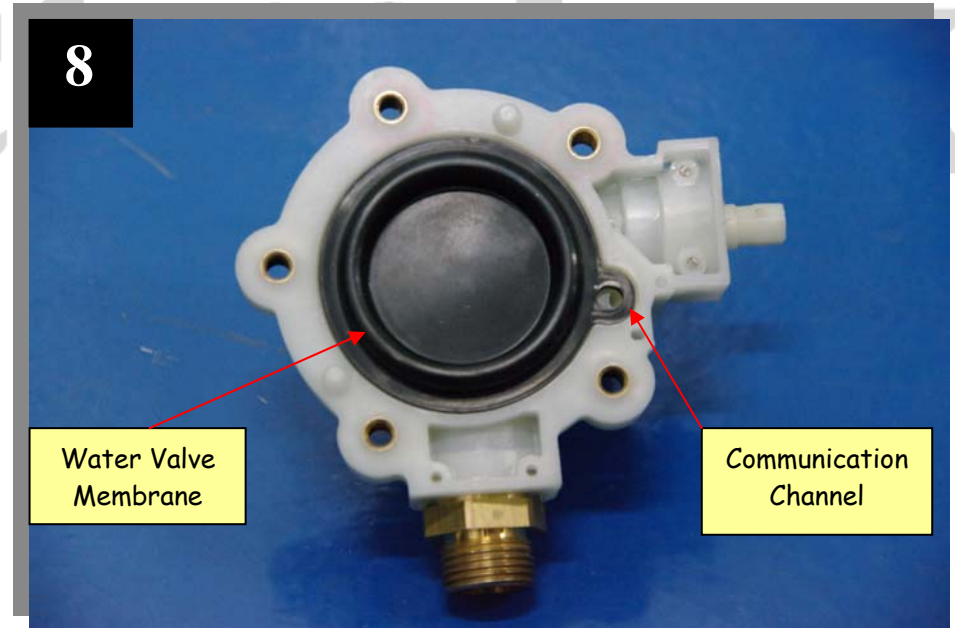
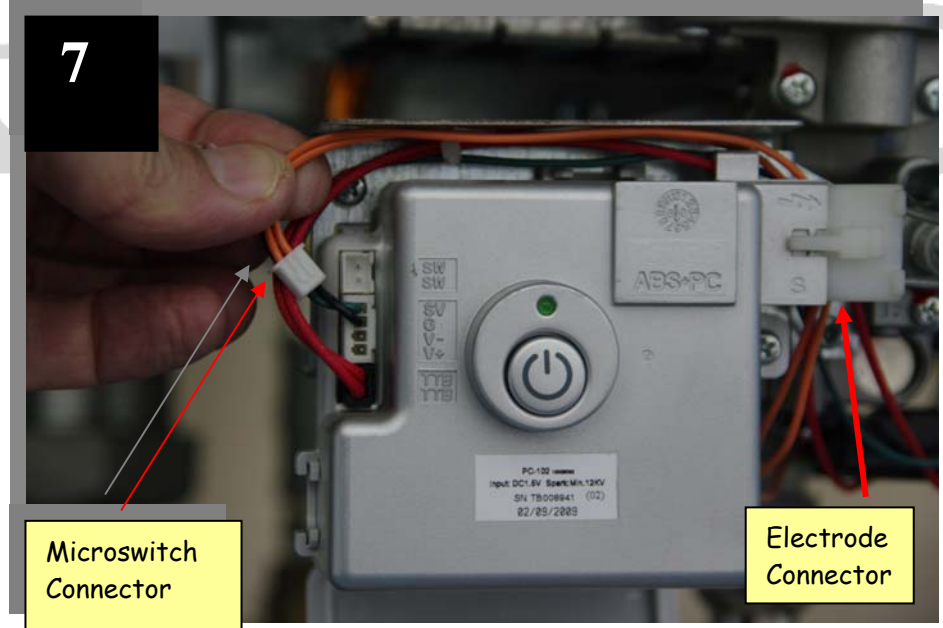
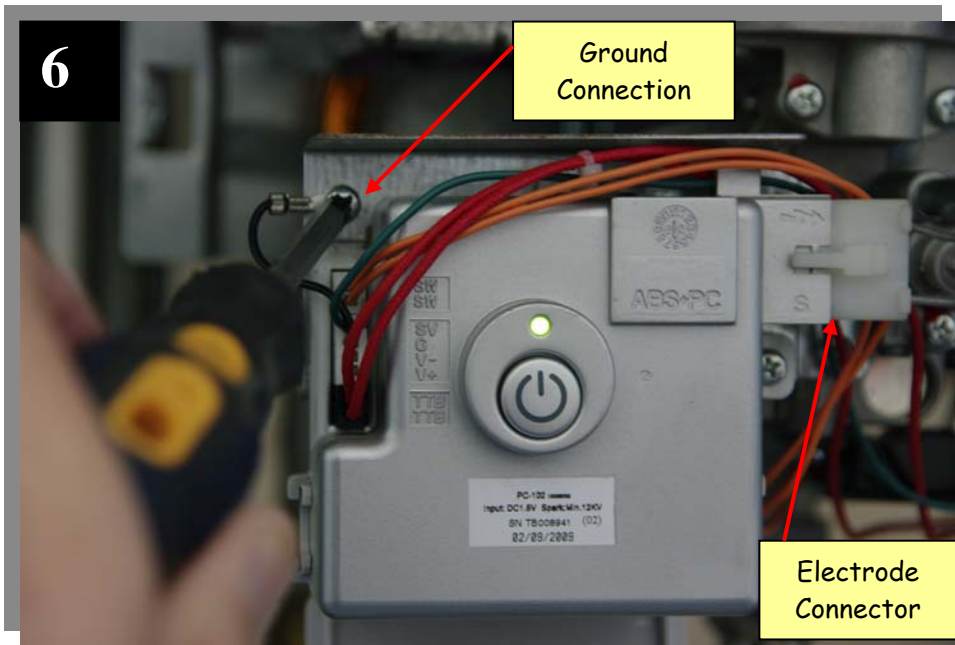
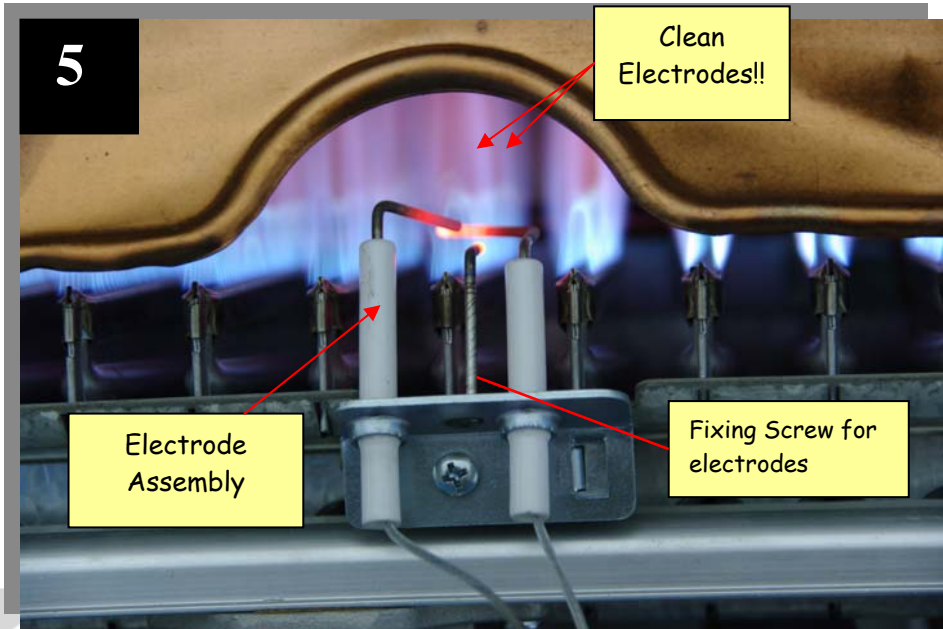

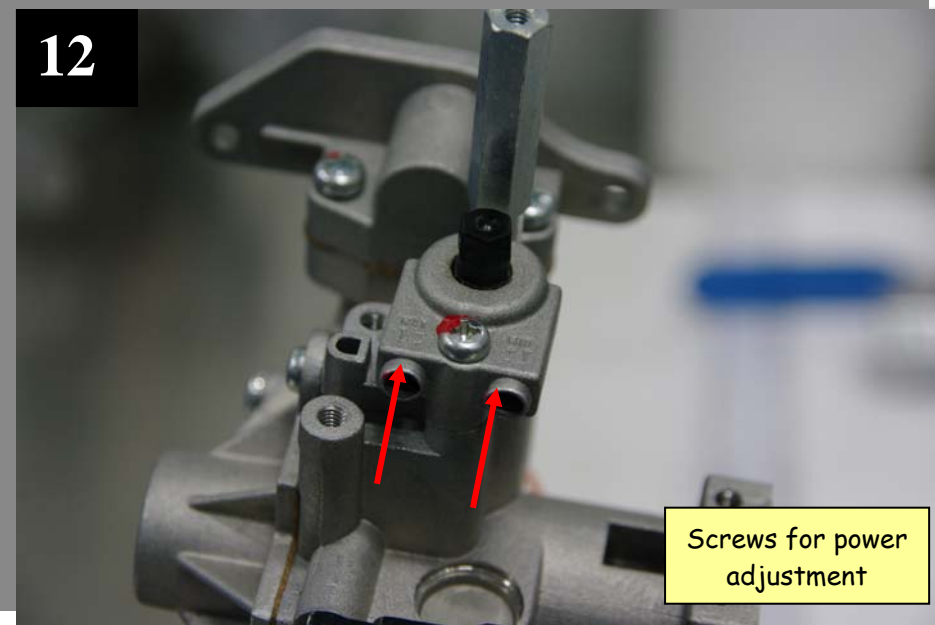
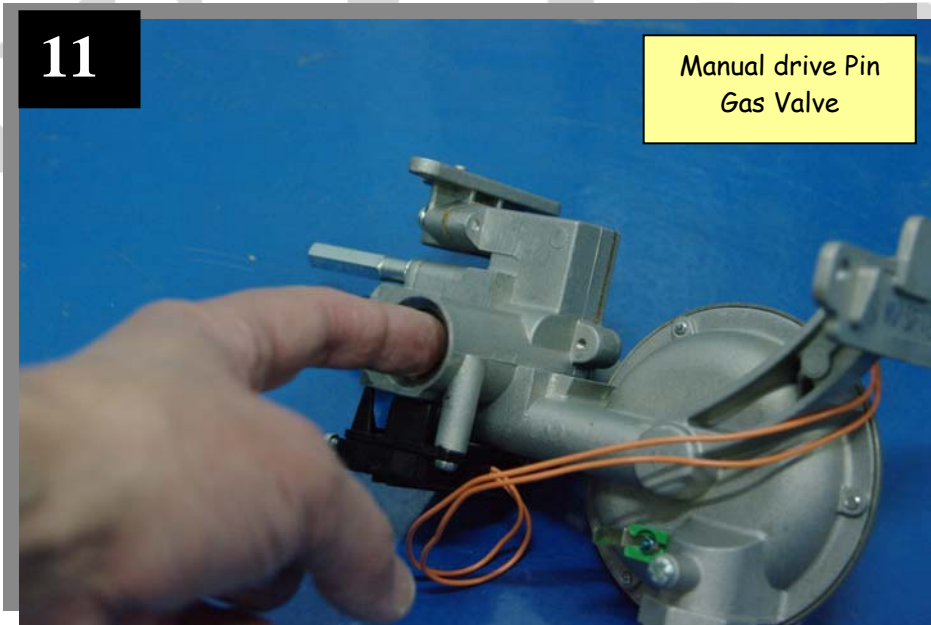
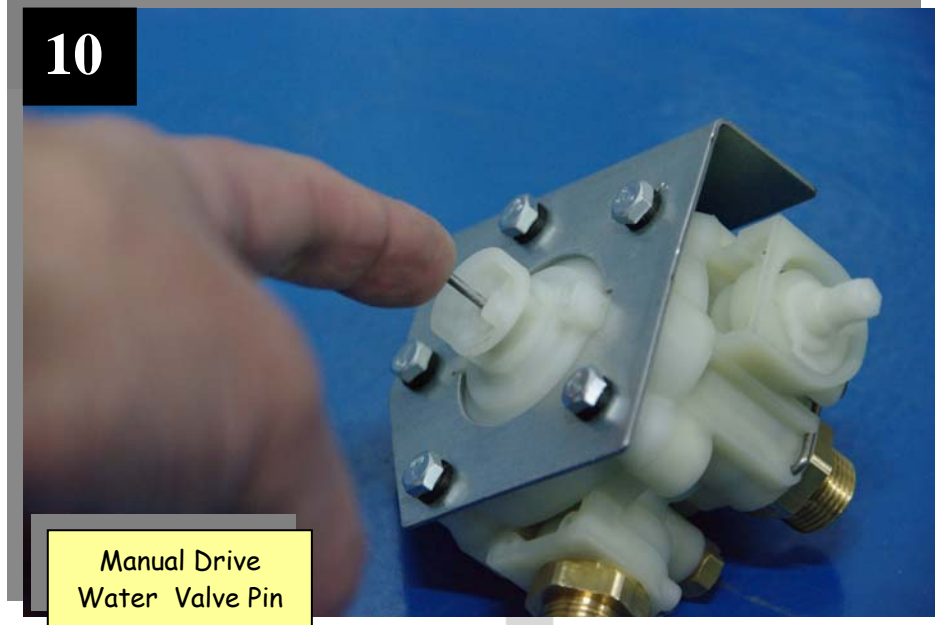
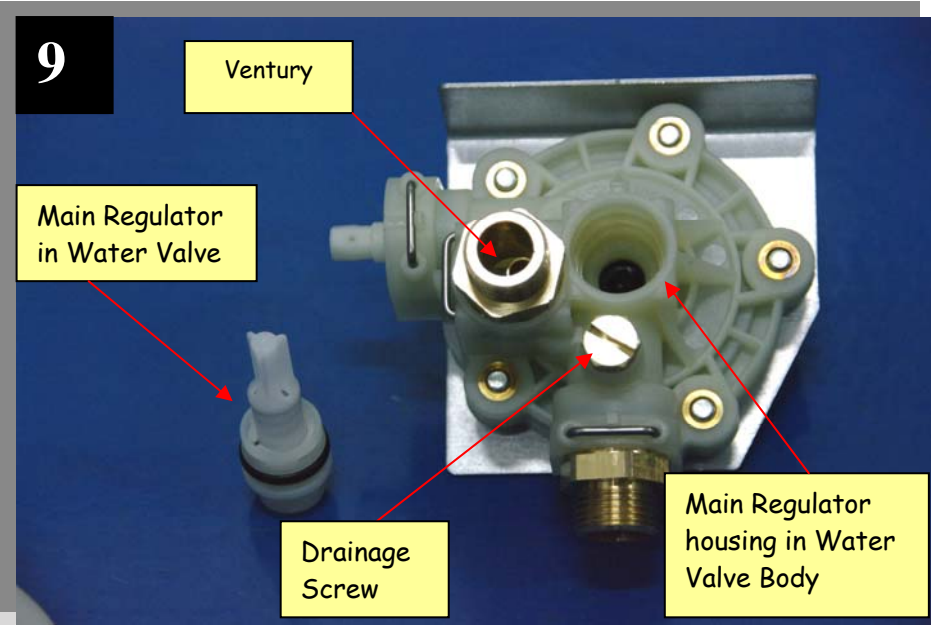

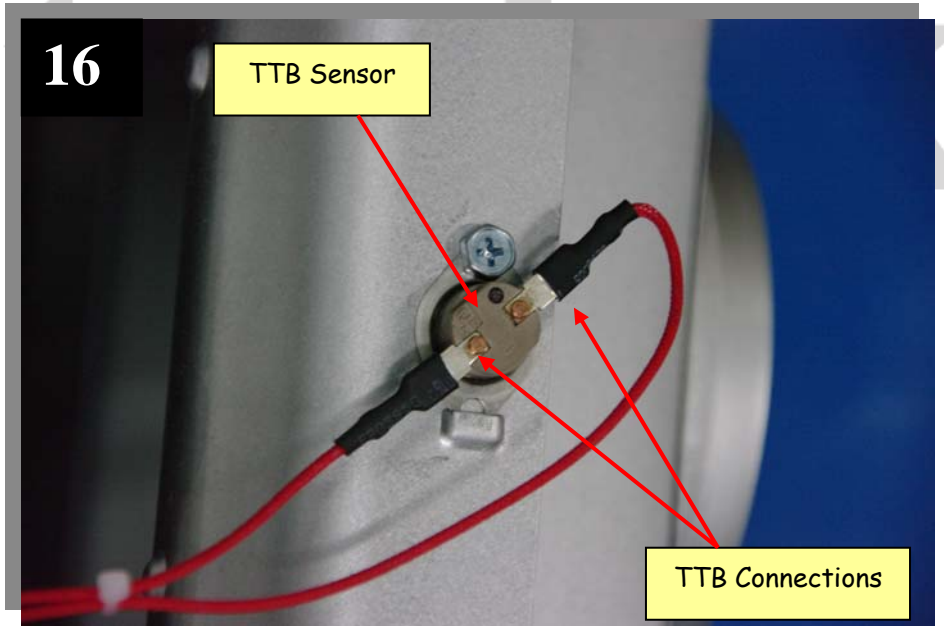
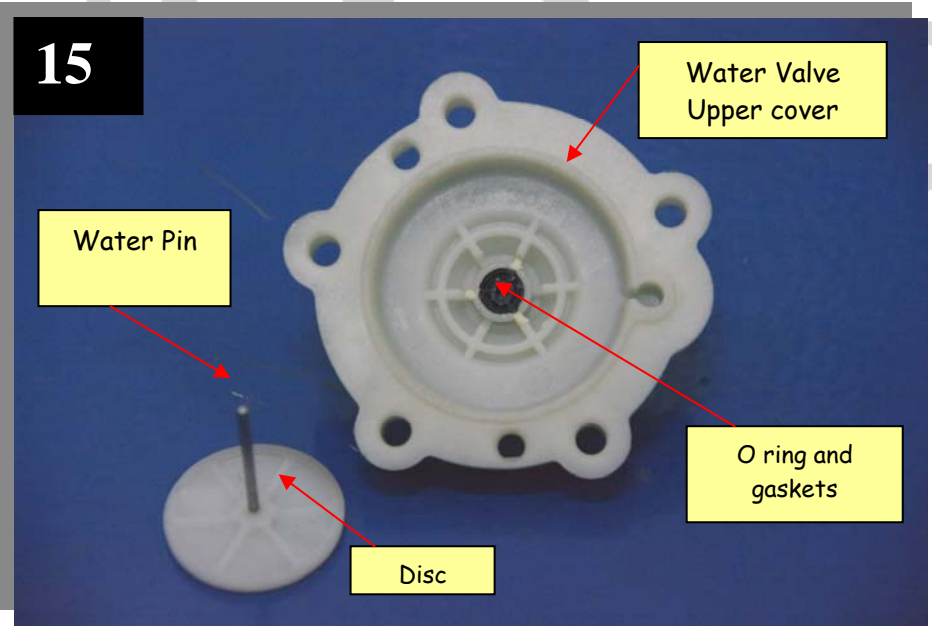
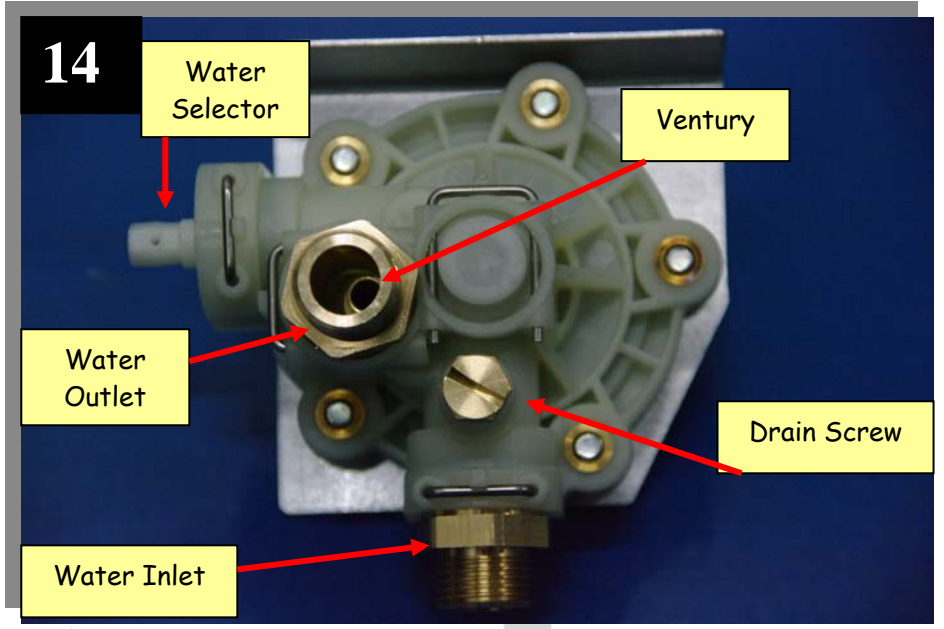
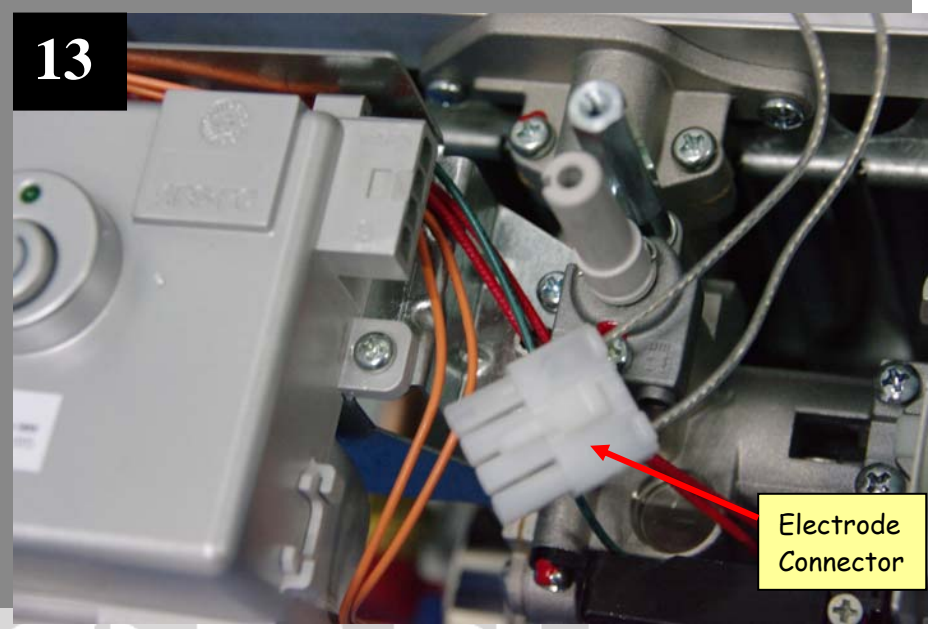

17

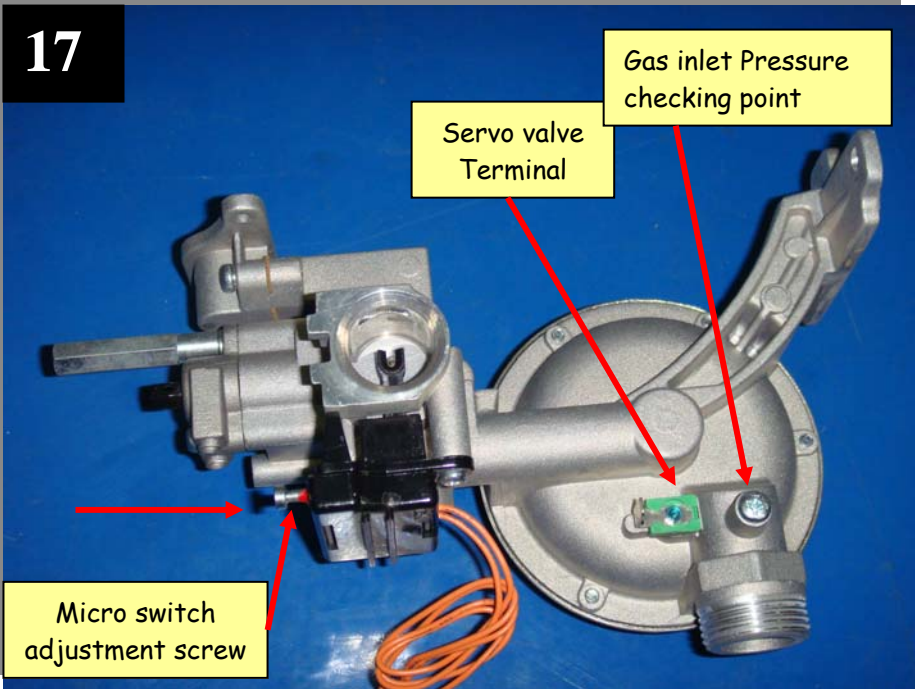

18

