

Operating Instructions

Please read these instructions carefully before using the appliance!



For your own safety

- Installation, commissioning and maintenance of this appliance may only be undertaken by an authorized professional who will then be responsible for adherence to the applicable standards and installation regulations.
- The appliance may only be used when correctly installed and in perfect working order!
- The appliance must be installed in a frost-free room!
- The appliance must be completely filled with water before being switched on!
- The appliance and its wiring and piping must not be modified in any way!
- The front cover of the appliance must never be opened before disconnecting the appliance from the mains power supply!
- Be careful! When the appliance has been in use for some time, the fittings may be very hot!
- The appliance must be earthed!

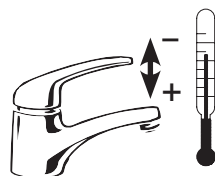

Description of appliance

The appliance is a pressure-type electronically controlled instantaneous heater for decentral water heating at one or two taps situated in close proximity to one another, e.g. kitchen sink or shower. Technical specifications → overleaf!

Use

The instantaneous water heater heats the water to the required temperature directly as it streams through. The heater switches on automatically when the threshold flow rate is exceeded. The „Power“ indicator (2) lights up when the heater is switched on. The „Pressure“ indicator (3) lights up when the flow rate is too low.

The power is automatically adjusted by the electronics in line with the water flow rate in order to obtain the set temperature and keep it virtually constant. The required temperature can be set to within one degree between 35 °C and 55 °C via the two buttons (5) and can be read off on the digital display (4).

If the full power of the instantaneous heater is not sufficient to heat the water to the required temperature, this is indicated by the flashing „Power“ indicator (2). The temperature can be restored by reducing the hot water flow rate at the tap.

At high feed temperatures, the power is automatically switched off by the electronics in order to avoid producing excessively hot water. This is indicated by the „Overheat“ lamp (1).



Venting

To prevent damage to the appliance, the instantaneous water heater must be vented before using it for the first time. Each time it is emptied (e.g. after work on the plumbing system, if there is a risk of frost or following repair work), the appliance must be re-vented before it is used again.

- 1 Disconnect appliance from the mains by removing the fuses.
- 2 Next, open and close the hot water tap valve several times until no more air emerges from the pipe and all air has been eliminated from the water heater (approx. 1 minute).
- 3 Only then should you re-connect the power supply to the unit.

Save energy

Set precisely the required temperature on the appliance and only open the hot water tap. If the water is too hot, set a lower temperature on the appliance instead of adding cold water. If you add cold water, the heated water is cooled again and valuable energy will be lost. Moreover, the cold water added in the fitting cannot be controlled by the electronics and a constant temperature can no longer be guaranteed.

Maintenance and cleaning

- Plastic surfaces and fittings may only be wiped with a damp cloth. Never use abrasive cleaning agents or solvents.
- For a good water supply, the aerators and shower heads should be unscrewed and cleaned or renewed at regular intervals.
- The electrical and plumbing components should be inspected by an authorized professional at least every three years to ensure proper functioning and operational safety at all times.

Cleaning the fine filter

In case of malfunctions, the filter in the cold water connecting piece should be inspected and cleaned or replaced if necessary.

Troubleshooting

If you experience a malfunction, please try to rectify the fault yourself first with the help of this table. If a fault in your appliance cannot be rectified with the aid of this table, please contact CLAGE who will either assist you directly or put you in touch with a customer service contract partner in your area. Always specify the appliance model and serial number, please!

Repairs may only be carried out by authorized professionals.

CLAGE GmbH
Customer Service
Pirloweg 1–5
D-21337 Lüneburg
Fon: +49 4131 8901-40
Fax: +49 4131 8901-41
E-mail: service@clage.de
Internet: http://www.clage.de

Problem	Possible Cause	Solution
LED remains off water remains cold	Circuit breaker tripped	Have the fault rectified and reset
The pilot lamp „Power“ lights, water remains cold	Heating element or electronics faulty	Reset fuse, Contact customer service
	Safety thermal cut-out tripped	Reset. In case of repeated trips contact customer service
The pilot lamp „Pressure“ lights, water remains cold	Flow rate too low	Increase flow pressure
	Water flows lower as expected	Depends on the heater Outlet fitting dirty or calcified Filter dirty or calcified Tap not suitable
The hot water is not hot enough	Electronic board	Reset fuse
	Flow rate is too high (winter?)	Reduce the water flow slightly
	Heating element defect	Contact customer service
Temperature and pressure vary	Cold water is being added	Only hot water can be delivered to within one degree

Layout of appliance and spareparts
When ordering, please always specify the appliance model,
nominal rating and serial number!

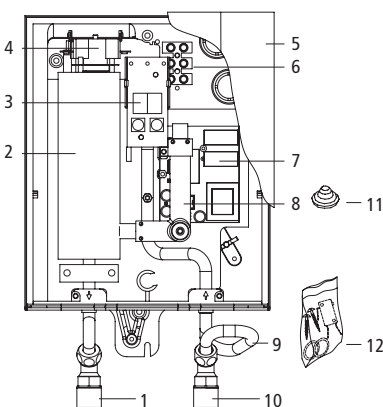

- | Pos. | Description |
|------|--|
| 1 | Hot water connecting piece |
| 2 | Heating element |
| 3 | Display panel |
| 4 | Safety thermal cut-out (STB) |
| 5 | Appliance hood |
| 6 | Connection terminal |
| 7 | Electronic board |
| 8 | Flow sensor |
| 9 | Cold water inlet |
| 10 | Cold water connecting piece with flow regulator, return flow inhibitor and filter |
| 11 | Cable seal |
| 12 | Set of small spare parts with seals, filter, screws and microswitch (not included in delivery, only on demand) |

Installation instructions for the authorized technician

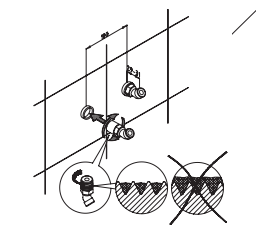
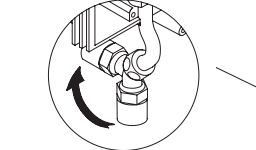
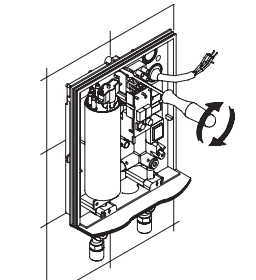
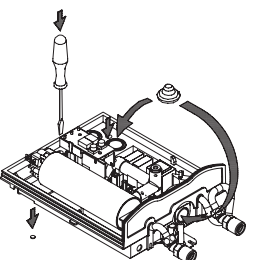
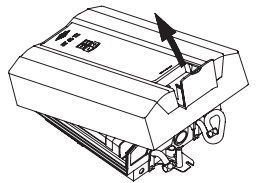
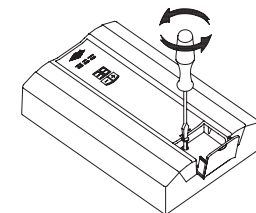

The following must be observed:

- The statutory regulations of the respective country, as well as those of the local electricity and water supply companies.
- The specifications on the rating plate and the technical specifications.

Installation site

- The installation site must be free from frost at all times.
- The appliance complies with protection type IP25 and may be installed in zone 1 acc. IEC
- In order to avoid thermal losses, the distance between the heater and the tapping point should be as small as possible (< 2 m).
- Best performance is guaranteed at a flow pressure of ≥ 3 bar, avoiding pressures exceeding 6 bar.
- Material of water pipes for tubular heater types:
cold water: steel or copper, hot water: copper

Installing the appliance:

- 1 Rinse water supply pipes thoroughly and turn off for installation.
- 2 Remove the front cover by unscrewing the locking screw behind the small lid.
- 3 Locate and break out the required holes and cable inlets. Mark the drilling holes with the appliance and drill them with a 6 mm drill bit.
- 4 Fit the rubber grommet supplied and insert the connecting lead. The lead must be secured with the cable clamp when using a flexible power cord.
- 5 Screw the appliance into position using the enclosed raw plugs and screws.

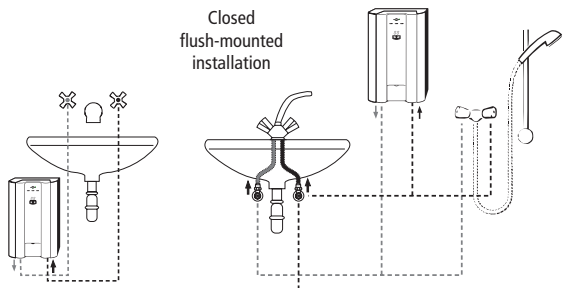

- 6 Install the appliance as shown in the principal examples above. The inlet and outlet are marked with arrows.
- 7 The water connections are designed for surface-mounted or flush-mounted installation. They must be carefully sealed with a little P.T.F.E. Tape when screwed into the wall connections.
- 8 The front cover must be neatly broken at the designated points when installed on the wall.
- 9 Open the water supply to the appliance and the tap to check all connections for leaks.
- 10 Next, open and close the hot water tap several times until no more air emerges from the line and all air has been eliminated from the heater.

Electrical connection:

The instantaneous water heater is an appliance of protection class I and must be connected to the protective earth conductor!

- 1 Check that the power supply is switched off prior to the electrical connection!

- The appliance must be connected to the supply by means of permanent wiring through suitable circuit breaker having a contact separation of at least 3 mm in all poles.

- The cross sectional area of the connection cable must be in accordance with the power rating.

- To protect the appliance, a fuse element must be fitted with a tripping current commensurate with the nominal current of the appliance.

- 2 The connection cable should be sealed with the cable seal and carefully connected to the terminal block using leads as well as the earth conductor.

- The connecting terminal can be transferred to the bottom of the appliance if necessary.

- The cable clamp can only be used for the model CRX 6. The connecting cable must not be strained when the cable clamp is not used.

- 3 Fit the front cover. Secure the front cover with the fastening screw.
- 4 Fill the appliance with water completely, switch on the power supply to the appliance.

- 5 Explain the use of the instantaneous water heater to the user and fold these instructions so that they can be stored behind the front panel.

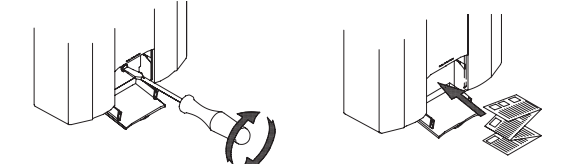
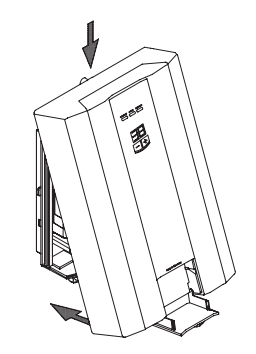
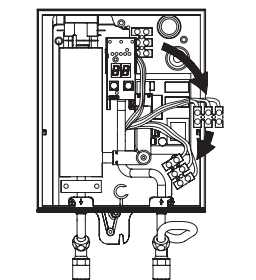
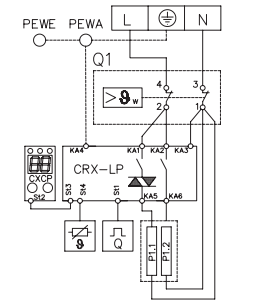

Replacing the flow regulator

In case you notice that the hot water flow rate is too low resp. the water heater does not switch on due to the low pressure of the incoming water at place please remove the flow regulator.

Technical specifications:

Type:	CRX 6	CRX 7	CRX 9
Water content	0.2 litre	0.2 litre	0.2 litre
Pressure-type, rating pressure	6 bar	6 bar	6 bar
Heating system	Tubular heater	Tubular heater	Tubular heater
Nominal rating	6.0kW/220 V	7.2 kW/220 V	8.0 kW/220 V
Rated voltage (50 / 60 Hz)	1/N/PE ~ 220..230V	1/N/PE ~ 220..230V	1/N/PE ~ 220..230V
Rated current at 220 V	27.3 A	32.7 A	36.4 A
Required conductor cross-section	3 x 4.0 mm ²	3 x 6.0 mm ²	3 x 6.0 mm ²
Switch-on flow	2 l/min	2 l/min	2 l/min
Max. hot water output at Δ t = 25 K ¹	3,8 l/min	4,1 l/min	5,0 l/min
Factory preset flow reducer	3,5 l/min	4,0 l/min	5,0 l/min
Increase of temperature Δ t	27 K	26 K	25 K
Hot water temperature at 15°C inlet temp.	42 °C	41 °C	40 °C
Temperature presetting	35 – 55 °C	35 – 55 °C	35 – 55 °C
Useful for cold water up to	30 °C	30 °C	30 °C
Water connection	1/2" B.S.P. surface-mounted or flush-mounted		
Net weight and dimensions (H x W x D)	2.2 kg / 33 x 21 x 9 cm		
Protection class and type of protection to VDE	1 / IP25		
Safety mark	see rating plate		

¹ Temperature increase of e.g. 20°C inlet temperature to 45°C outlet temperature at 230 V